

FEATURES

- | SOT-23 Package Allows Either Two Separate Unidirectional Configurations or a Single Bidirectional Configuration
- | Working peak reverse voltage 3V to 26V
- | Standard Zener breakdown voltage 5.6V to 33V
- | Peak power 24 or 40 Watts @ 1.0ms (unidirectional) per Figure 5 Waveform
- | ESD Rating of Class N (exceeding 16KV) per the Human Body Model
- | Maximum Clamping Voltage @ Peak Pulse Current
- | Meet AEC-Q101 Requirements

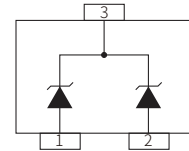

SOT-23



Schematic Symbol

MECHANICAL DATA

- | SOT-23 Package
- | Flammability Rating: UL 94V-0

APPROVALS

RoHS	Compliance with 2011/65/EU
HF	Compliance with IEC61249-2-21:2003

MAXIMUM RATINGS ($T_A=25^{\circ}\text{C}$)

Parameter	Symbol	Value	Unit
Total Power Dissipation on FR-5 Board (Note 2) @ $T_A=25^{\circ}\text{C}$ Derate above 25°C	P_D	225	mW
		1.8	mW/ $^{\circ}\text{C}$
Thermal Resistance Junction-to-Ambient	$R_{\theta JA}$	556	$^{\circ}\text{C}/\text{W}$
Total Power Dissipation on Alumina Substrate (Note 3) @ $T_A=25^{\circ}\text{C}$ Derate above 25°C	P_D	300	mW
		2.4	mW/ $^{\circ}\text{C}$
Thermal Resistance Junction-to-Ambient	$R_{\theta JA}$	417	$^{\circ}\text{C}/\text{W}$
Peak Power Dissipation @ 1.0ms (Note 1) $T_L \leq 25^{\circ}\text{C}$	P_{PK}	MMBZ5V6CLQ-MMBZ10VCLQ 24	W
		MMBZ12VCLQ-MMBZ33VCLQ 40	W
Junction and Storage temperature range	T_J, T_{STG}	-55 to +150	$^{\circ}\text{C}$

Maximum ratings are those values beyond which device damage can occur. Maximum ratings applied to the device are individual stress limit values (not normal operating conditions) and are not valid simultaneously. If these limits are exceeded, device functional operation is not implied, damage may occur and reliability may be affected.

1, Non-repetitive current pulse per Figure 5 and derate above $T_A=25^{\circ}\text{C}$ per Figure 6;

2, FR-5 = 1.0 x 0.75 x 0.62 in;

3, Alumina = 0.4 x 0.3 x 0.024 in, 99.5% alumina

* Other voltages may be available upon request.

ELECTRICAL CHARACTERISTICS

Part Number	Device Marking Code	V _{RWM}	I _R @V _{RWM}	Breakdown Voltage			Max Zener Impedance(Note5)			V _C @I _{PP} (Note6)		θV _{BR}	
				V _{BR} (Note4)(V)			@ I _T	Z _{Z1} @I _{ZT}	Z _{ZK} @I _{ZK}	V _C	I _{PP}		
				Min	Nom	Max	(mA)	(Ω)	(Ω)	(mA)	(V)		(A)
24 WATTS													
MMBZ5V6CLQ	5C6	3.0	5.0	5.32	5.6	5.88	20	11	1600	0.25	8.0	3.0	1.26
MMBZ6V2CLQ	6C2	3.0	0.5	5.89	6.2	6.51	1.0	-	-	-	8.7	2.76	2.80
MMBZ6V8CLQ	6C8	4.5	0.5	6.46	6.8	7.14	1.0	-	-	-	9.6	2.5	3.4
MMBZ9V1CLQ	9C1	6.0	0.3	8.65	9.1	9.56	1.0	-	-	-	14	1.7	7.5
MMBZ10VCLQ	10C	6.5	0.3	9.50	10	10.5	1.0	-	-	-	14.2	1.7	7.5
40 WATTS													
MMBZ12VCLQ	12C	8.5	200	11.40	12	12.60	1.0	-	-	-	17	2.35	7.5
MMBZ15VCLQ	15C	12.0	50	14.25	15	15.75	1.0	-	-	-	21	1.90	12.3
MMBZ18VCLQ	18C	14.5	50	17.10	18	18.90	1.0	-	-	-	25	1.60	15.3
MMBZ20VCLQ	20C	17.0	50	19.00	20	21	1.0	-	-	-	28	1.4	17.2
MMBZ27VCLQ	27C	22.0	50	25.65	27	28.35	1.0	-	-	-	41	1.0	24.3
MMBZ33VCLQ	33C	26.0	50	31.35	33	34.65	1.0	-	-	-	46	0.87	30.4

4, V_{BR} measured at pulse test current I_T at an ambient temperature of 25°C

5, Z_{Z1} and Z_{ZK} are measured by dividing the AC voltage drop across the device by the AC current applied. The specified limits are for I_{Z(AC)}=0.1 I_Z(DC), with the AC frequency = 1.0kHz.

6, Surge current waveform per Figure 5 and derate Figure 6

CHARACTERISTIC CURVES

Typical Breakdown Voltage Versus Temperature

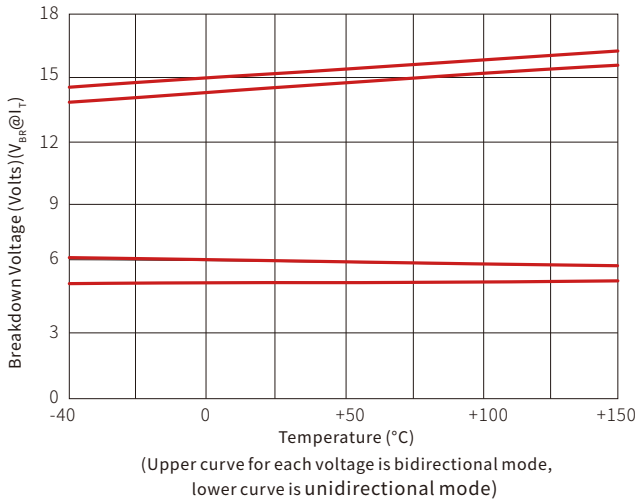

Typical Leakage Current Versus Temperature

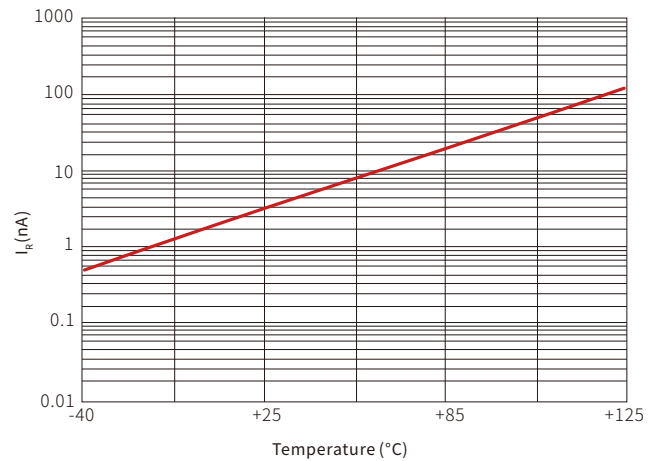

Typical Capacitance Versus Bias Voltage

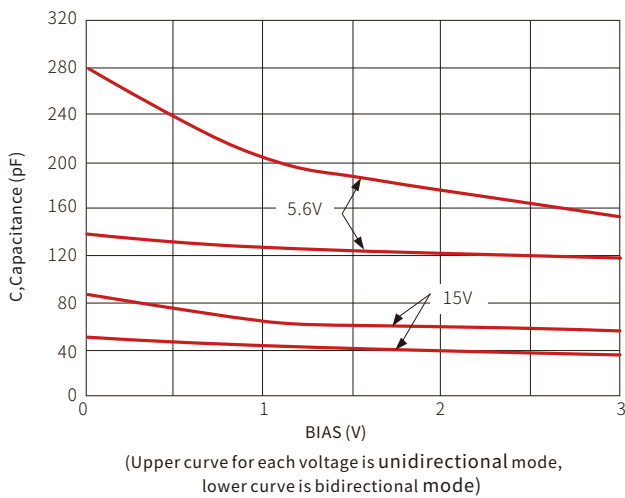

Pulse Derating Curve

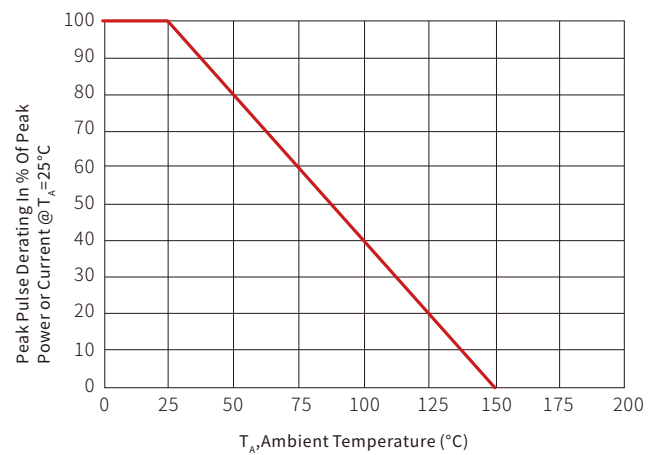

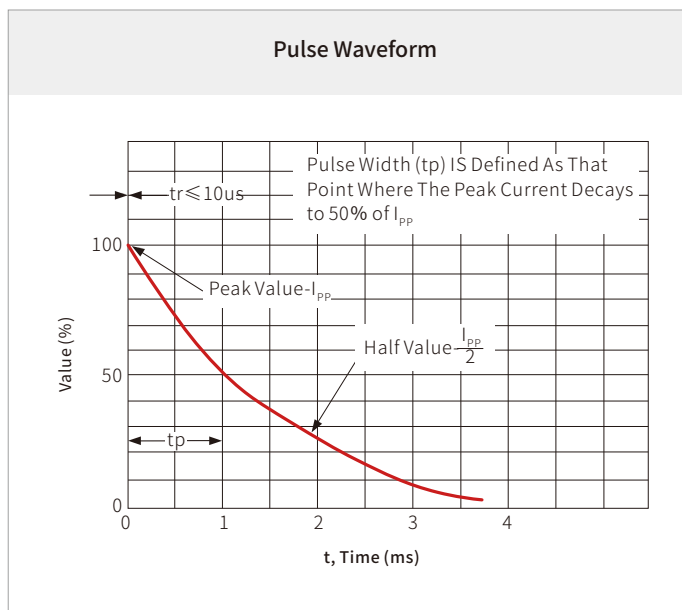
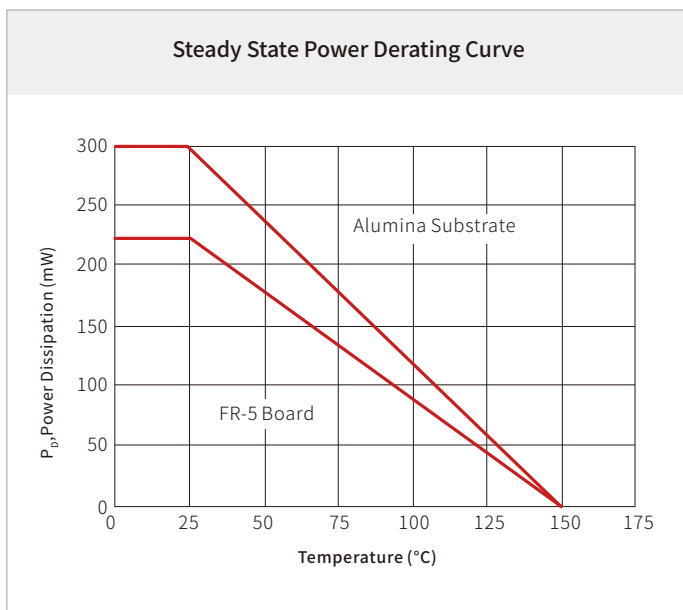

SOLDERING PARAMETERS

Reflow Condition		Lead-free assembly
Pre Heat	Temperature Max ($T_{s(min)}$)	150°C
	Temperature Max ($T_{s(max)}$)	200°C
	Time (min to max) (t_s)	60 – 180 secs
Average ramp up rate (Liquidus Temp (T_L) to peak)		3°C/second max
$T_{s(max)}$ to T_L - Ramp-up Rate		3°C/second max
Reflow	Temperature (T_L) (Liquidus)	217°C
	Time (min to max) (t_L)	60 – 150 seconds
Peak Temperature (T_p)		260°C
Time within 5°C of actual peak Temperature (t_p)		20 – 40 seconds
Ramp-down Rate		6°C/second max
Time 25°C to peak Temperature (T_p)		8 minutes max.
Do not exceed		260°C

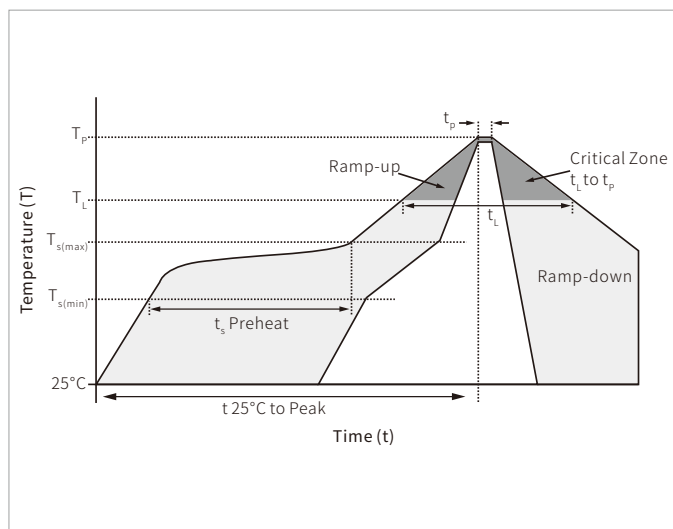

SOT-23 PACKAGE INFORMATION

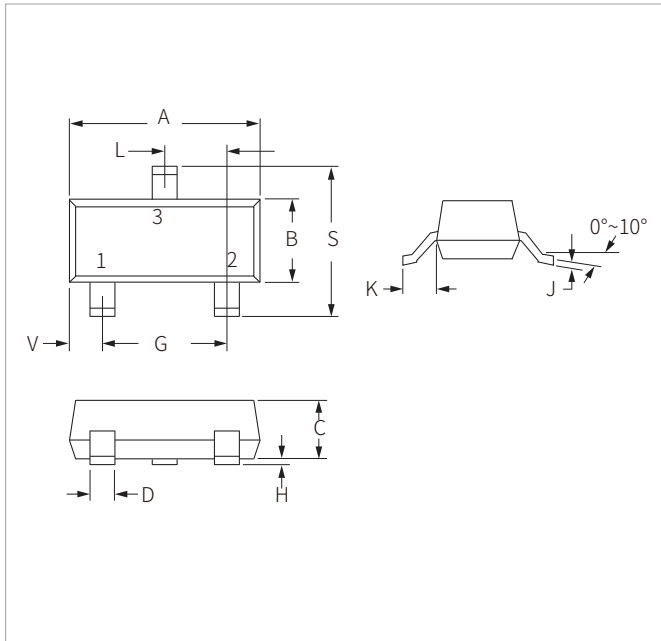

Ref.	Millimeters		Inches	
	Min.	Max.	Min.	Max.
A	2.80	3.05	0.110	0.120
B	1.20	1.40	0.047	0.055
C	0.90	1.15	0.035	0.045
D	0.37	0.50	0.015	0.020
G	1.75	2.05	0.069	0.081
H	0.01	0.100	0.001	0.004
J	0.085	0.180	0.003	0.007
K	0.35	0.69	0.014	0.029
L	0.89	1.02	0.035	0.040
S	2.10	2.65	0.083	0.104
V	0.45	0.60	0.018	0.024

RECOMMENDED PAD LAYOUT DIMENSIONS

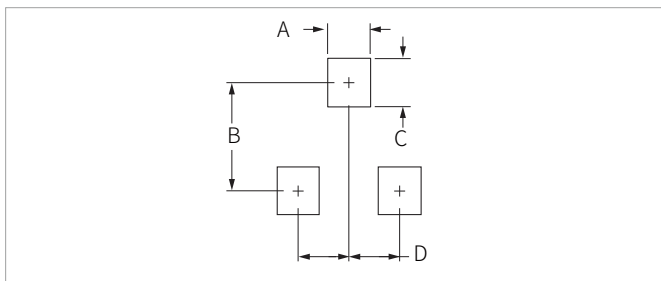

Ref.	Millimeters		Inches	
	Min.	Max.	Min.	Max.
A	0.71	0.97	0.028	0.038
B	1.88	2.13	0.074	0.084
C	0.71	0.97	0.028	0.038
D	0.81	1.07	0.032	0.042

ORDERING INFORMATION

Part Number	Component Package	QTY/Reel	Reel Size
MMBZxxxVCLQ	SOT-23	3000PCS	7"

Headquarters

No.3387 Shendu Road
Pujiang I&E Park
Minhang Shanghai China
201000

Hotline

400-021-5756

Web

<https://www.semiware.com>

Sales Center

Tel: 86-21-3463-7458
Email: sales18@semiware.com

Customer Service

Tel: 86-21-5484-1001
Email: sales17@semiware.com

Technical Support

Tel: 86-21-3463-7654
Email: fae01@semiware.com

Complaint & Suggestions

Tel: 86-21-3463-7172
Ext: 8868
Email: cs03@semiware.com

By QR Code

Website



Wechat

To find your local partner within Semiware' s global website: www.semiware.com

© 2022 Semiware Semiconductor Inc.

The content of this document has been carefully checked and understood. However, neither Semiware nor its subsidiaries assume any liability whatsoever for any errors or inaccuracies of this document and the consequences thereof. Published specifications are subject to change without notice. Product suitability for any area of application must ultimately be determined by the customer. In all cases, products must never be operated outside their published specifications. Semiware does not guarantee the availability of all published products. This disclaimer shall be governed by substantive Chinese law and resulting disputes shall be settled by the courts at the place of business of Semiware. Latest publications and a complete disclaimer can be downloaded from the Semiware website. All trademarks recognized.