

FEATURES

- | High surge current handling capability
- | High energy absorption capability
- | Wide operating voltages ranging from 10Vrms to 680Vrms
- | Fast response time of less than 25ns, instantly clamping the transient over voltage
- | Low clamping voltages, providing better surge protection
- | Low capacitance values, providing digital switching circuitry protection
- | High insulation resistance, preventing electric arcing to the adjacent devices or circuits

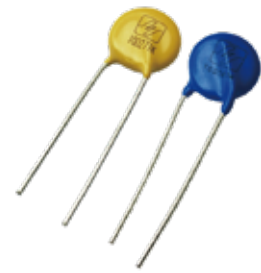

10D

APPLICATIONS

- | Surge protection of consumer equipment
- | Surge protection of communication, measuring and controller instrument
- | Surge protection in electronic home appliances, gas and petroleum appliances
- | Relay and electromagnetic valve surge absorption
- | Transistor, Diode, IC, Thyristor or Triac semiconductor protection

APPROVALS

RoHS	Compliance with 2011/65/EU
HF	Compliance with IEC61249-2-21:2003

GENERAL CHARACTERISTICS DEFINITION

- | Operating Temperature Range : -40°C ~ +125°C
- | Storage Temperature Range : -40°C ~ +150°C
- | Working Surface Temperature : +115°C
- | Insulation Resistance : >100MΩ

MATERIAL

- | Coating: Epoxy Resin
- | Electrode: Silver Solder
- | Disk: Zinc Oxide

ELECTRICAL CHARACTERISTICS

Symbol		Mximum Allowable Voltage		Varistor Voltage @1mA	Mximum Clamping Voltage		Withstanding Surge Current (8/20µs)		Maximum Energy (10/1000µs)		Rated Power	Typical Capacitance (Reference)
Standard	High Surge	V _{ac} (V)	V _{dc} (V)	(V)	V _c (V)	I _p (A)	I(A) Standard	I(A) High Surge	(J) Standard	(J) High Surge	(W)	@1KHz (pF)
10D180L	10D180LJ	10	14	18(15-21)	38	5	500	1000	2.8	3.0	0.05	5600
10D220K	10D220KJ	14	18	22(20-24)	43	5	500	1000	4.5	5.0	0.05	4500
10D270K	10D270KJ	17	22	27(24-30)	53	5	500	1000	6.0	6.5	0.05	3700
10D330K	10D330KJ	20	26	33(30-36)	65	5	500	1000	7.4	8.0	0.05	3000
10D390K	10D390KJ	25	31	39(35-43)	77	5	500	1000	9.1	9.5	0.05	2600
10D470K	10D470KJ	30	38	47(42-52)	93	5	500	1000	10.8	11.0	0.05	2100
10D560K	10D560KJ	35	45	56(50-62)	110	5	500	1000	12.9	13.0	0.05	1800
10D680K	10D680KJ	40	56	68(61-75)	135	5	500	1000	15.4	16.0	0.05	1500
10D820K	10D820KJ	50	65	82(74-90)	135	25	2500	3500	16.8	17.0	0.4	1200
10D101K	10D101KJ	60	85	100(90-110)	165	25	2500	3500	18.2	18.5	0.4	1000
10D121K	10D121KJ	75	100	120(108-132)	200	25	2500	3500	21.0	21.5	0.4	830
10D151K	10D151KJ	95	125	150(135-165)	250	25	2500	3500	25.2	26.0	0.4	670
10D181K	10D181KJ	115	150	180(162-198)	300	25	2500	3500	30.8	38.0	0.4	560
10D201K	10D201KJ	130	170	200(185-225)	330	25	2500	3500	42.0	42.5	0.4	500
10D221K	10D221KJ	140	180	220(198-242)	360	25	2500	3500	46.2	46.5	0.4	450
10D241K	10D241KJ	150	200	240(216-262)	395	25	2500	3500	50.4	51.0	0.4	420
10D271K	10D271KJ	175	225	270(243-297)	455	25	2500	3500	57.4	58.0	0.4	370
10D301K	10D301KJ	190	250	300(270-330)	505	25	2500	3500	63.0	63.5	0.4	330
10D331K	10D331KJ	210	275	330(297-363)	550	25	2500	3500	68.6	69.0	0.4	300
10D361K	10D361KJ	230	300	360(324-396)	595	25	2500	3500	74.2	75.0	0.4	280
10D391K	10D391KJ	250	320	390(351-429)	650	25	2500	3500	81.2	82.0	0.4	260
10D431K	10D431KJ	275	350	430(387-473)	710	25	2500	3500	88.2	89.0	0.4	230
10D471K	10D471KJ	300	385	470(423-517)	775	25	2500	3500	96.0	100	0.4	210
10D511K	10D511KJ	320	415	510(459-561)	845	25	2500	3500	98.0	102	0.4	200
10D561K	10D561KJ	350	460	560(504-616)	920	25	2500	3500	100	104	0.4	180
10D621K	10D621KJ	385	505	620(558-682)	1025	25	2500	3500	102	106	0.4	160
10D681K	10D681KJ	420	560	680(612-748)	1120	25	2500	3500	104	108	0.4	150
10D751K	10D751KJ	460	615	750(675-825)	1240	25	2500	3500	110	118	0.4	140

Symbol		Mximum Allowable Voltage		Varistor Voltage @1mA	Mximum Clamping Voltage		Withstanding Surge Current (8/20µs)		Maximum Energy (10/1000µs)		Rated Power	Typical Capacitance (Reference)
Standard	High Surge	V _{AC} (V)	V _{DC} (V)	(V)	V _c (V)	I _p (A)	I(A) Standard	I(A) High Surge	(J) Standard	(J) High Surge	(W)	@1KHz (pF)
10D781K	10D781KJ	485	640	780(702-858)	1290	25	2500	3500	118	120	0.4	130
10D821K	10D821KJ	510	670	820(738-902)	1355	25	2500	3500	122	125	0.4	120
10D911K	10D911KJ	550	745	910(819-1001)	1500	25	2500	3500	128	134	0.4	110
10D102K	10D102KJ	625	825	1000(900-1100)	1650	25	2500	3500	131	140	0.4	100
10D112K	10D112KJ	680	895	1100(990-1210)	1815	25	2500	3500	133	155	0.4	90

CHARACTERISTIC CURVES

Items	Test condition/Description					
Varistor Voltage	The voltage across the varistor measured at 1mA DC, can be called Vb					
Maximum Allowable Voltage	Maximum continuous sine wave(RMS) or DC voltage which may be applied					
Maximum Clamping Voltage	Peak voltage across the varistor with a specified peak impulse current of 8/20µs waveform					
Rated Power	The maximum average power that can be applied within the specified ambient temperature					
Withstanding Surge Current	The maximum current within the varistor voltage change of less than ±10% when one impulse current(8/20µs) applied					
Energy	The max.energy absorbed with a varistor voltage change of less than ± 10% when one impulse (10/1000µs) is applied					
Varistor Voltage Temperature Coefficient	$\left \frac{Vb@85^{\circ}C - Vb@25^{\circ}C}{Vb@25^{\circ}C} \times \frac{1}{60} \times 100\% (\%/^{\circ}C) \right \leq 0.05\% / ^{\circ}C$ $\left \frac{Vb@-40^{\circ}C - Vb@25^{\circ}C}{Vb@25^{\circ}C} \times \frac{1}{65} \times 100\% (\%/^{\circ}C) \right \leq 0.05\% / ^{\circ}C$					
Surge Life	The max.current with a varistor voltage change of less than ±10% when 10,000 times impulse current (8/20µs) are applied at intervals of 20 seconds at room temperature <table border="1" style="margin-left: auto; margin-right: auto;"> <tr> <td rowspan="2">10D Series</td> <td>180L to 680K</td> <td>50A(8/20µs)</td> </tr> <tr> <td>820K to 112K</td> <td>100A(8/20µs)</td> </tr> </table>	10D Series	180L to 680K	50A(8/20µs)	820K to 112K	100A(8/20µs)
10D Series	180L to 680K		50A(8/20µs)			
	820K to 112K	100A(8/20µs)				

CHARACTERISTIC CURVES

Items	Test condition/Description	Specifications													
High Temperature Storage	Ambient Temp:125±2°C Duration:1000 hrs	$ \Delta V_{1_{mA}}/V_{1_{mA}} \leq 5\%$													
Low Temperature Storage	Ambient Temp:-40±2°C Duration:1000 hrs	$ \Delta V_{1_{mA}}/V_{1_{mA}} \leq 5\%$													
Humidity	Ambient Temp:40±2°C,90~95% R.H. Duration:1000 hrs	$ \Delta V_{1_{mA}}/V_{1_{mA}} \leq 5\%$													
Temperature Cycle	The conditions shown below shall be repeated 5 cycles	No visible damage $ \Delta V_{1_{mA}}/V_{1_{mA}} \leq 5\%$													
	<table border="1"> <thead> <tr> <th>Step</th> <th>Temperature(°C)</th> <th>Period(minutes)</th> </tr> </thead> <tbody> <tr> <td>1</td> <td>-40±3</td> <td>30±3</td> </tr> <tr> <td>2</td> <td>Room temperature</td> <td>15±3</td> </tr> <tr> <td>3</td> <td>125±3</td> <td>30±3</td> </tr> <tr> <td>4</td> <td>Room temperature</td> <td>15±3</td> </tr> </tbody> </table>		Step	Temperature(°C)	Period(minutes)	1	-40±3	30±3	2	Room temperature	15±3	3	125±3	30±3	4
Step	Temperature(°C)	Period(minutes)													
1	-40±3	30±3													
2	Room temperature	15±3													
3	125±3	30±3													
4	Room temperature	15±3													
High Temperature Load	Ambient Temp:85±2°C ,Duration:1000 hrs Load:Max.Allowable Voltage in AC eara	$ \Delta V_{1_{mA}}/V_{1_{mA}} \leq 10\%$													
Damp Heat Load	Ambient Temp:40±2°C ,90~95% R.H. Duration:1000 hrs Load:Max.Allowable Voltage	No visible damage $ \Delta V_{1_{mA}}/V_{1_{mA}} \leq 10\%$													
Voltage Proof	Metal balls method,2500Vac 1min	No visible damage													

WAVE SOLDERING

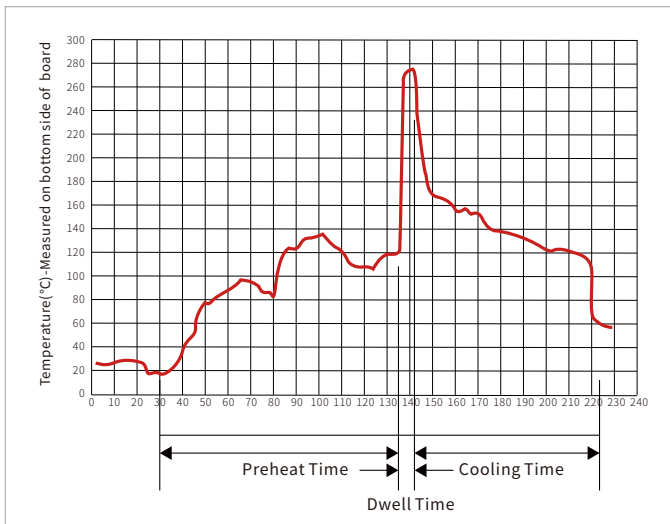

Wave Parameter		Lead-free assembly
Pre Heat	Temperature Min	100°C
	Temperature Max	150°C
	Time(min to max)	60 – 180 secs
Solder pot Temperature		280°C Max
Solder Dwell Time		2-5 seconds

PACKAGE INFORMATION

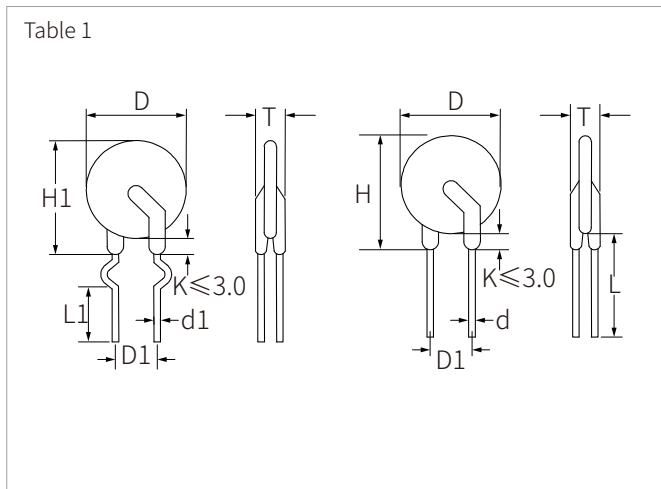

Symbol	Dimension(mm)
H(max)	17.0
H1(max)	17.5
L(min)	20.0
L1(min)	15.0
D(max)	12.5
D1(±0.8)	7.5
T(max)	Table2
d(±0.05)	0.8
d1(±0.4)	1.4

Table 2		Tmax(mm)					
10D180L	4.5	10D101K	4.3	10D331K	4.8	10D751K	6.5
10D220K	4.5	10D121K	4.5	10D361K	5.0	10D781K	6.6
10D270K	4.5	10D151K	4.8	10D391K	5.1	10D821K	6.8
10D330K	4.5	10D181K	4.1	10D431K	5.3	10D911K	7.2
10D390K	4.5	10D201K	4.1	10D471K	5.6	10D102K	7.6
10D470K	4.5	10D221K	4.2	10D511K	5.8	10D112K	7.8
10D560K	4.5	10D241K	4.3	10D561K	6.2		
10D680K	4.5	10D271K	4.5	10D621K	6.4		
10D820K	4.1	10D301K	4.7	10D681K	6.4		

ORDERING INFORMATION

Part Number	Component Package	Package
10D SERIES	10D	500PCS

Headquarters

No.3387 Shendu Road
Pujiang I&E Park
Minhang Shanghai China
201000

Hotline

400-021-5756

Web

<https://www.semiware.com>

Sales Center

Tel: 86-21-3463-7458
Email: sales18@semiware.com

Customer Service

Tel: 86-21-5484-1001
Email: sales17@semiware.com

Technical Support

Tel: 86-21-3463-7654
Email: fae01@semiware.com

Complaint & Suggestions

Tel: 86-21-3463-7172
Ext: 8868
Email: cs03@semiware.com

By QR Code

Website



Wechat

To find your local partner within Semiware's global website: www.semiware.com

© 2022 Semiware Semiconductor Inc.

The content of this document has been carefully checked and understood. However, neither Semiware nor its subsidiaries assume any liability whatsoever for any errors or inaccuracies of this document and the consequences thereof. Published specifications are subject to change without notice. Product suitability for any area of application must ultimately be determined by the customer. In all cases, products must never be operated outside their published specifications. Semiware does not guarantee the availability of all published products. This disclaimer shall be governed by substantive Chinese law and resulting disputes shall be settled by the courts at the place of business of Semiware. Latest publications and a complete disclaimer can be downloaded from the Semiware website. All trademarks recognized.