

## FEATURES

- |  $V_{DS} = 30V, I_D = 5.6A$

---

- |  $R_{DS(ON)} < 27\ m\Omega @ V_{GS} = 10V$

---

- |  $R_{DS(ON)} < 30m\Omega @ V_{GS} = 4.5V$

---

- |  $R_{DS(ON)} < 45m\Omega @ V_{GS} = 2.5V$

---

- | Trench Power LV MOSFET technology

---

- | High density cell design for low  $R_{DS(ON)}$

---

- | High Speed switching

---

- | Meet AEC-Q101 Requirements

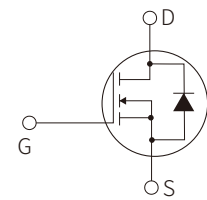
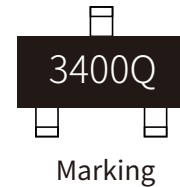

Schematic Symbol

## APPLICATION

- | Battery protection

---

- | Load switch

---

- | Power management

## APPROVALS

<b>RoHS</b>	Compliance with 2011/65/EU
<b>HF</b>	Compliance with IEC61249-2-21:2003

## ABSOLUTE MAXIMUM RATINGS

Parameter	Symbol	Value	Unit
Drain-Source Voltage	$V_{DS}$	30	V
Gate Threshold Voltage	$V_{GSS}$	$\pm 12$	V
Drain Current - Continuous ( $T_A = 25^\circ C$ )	$I_D$	5.6	A
Drain Current - Continuous ( $T_A = 70^\circ C$ )		4.5	
Pulsed Drain Current <sup>A</sup>	$I_{DM}$	23	A
Power Dissipation ( $T_A = 25^\circ C$ )	$P_D$	1.2	W
Power Dissipation ( $T_A = 70^\circ C$ )		0.8	
Thermal Resistance Junction- to- Ambient <sup>B</sup>	$R_{\theta JA}$	104	$^\circ C/W$
Operating Junction and Storage Temperature Range	$T_J, T_{STG}$	-55 to 150	$^\circ C$

## ELECTRICAL CHARACTERISTICS (Ta=25°C )

Parameter	Symbol	Test Conditions	Min	Typ	Max	Unit
<b>Static Parameter</b>						
Drain-Source Breakdown Voltage	$BV_{DSS}$	$V_{GS}=0V, I_D=250\mu A$	30			V
Gate-source leakage current	$I_{GSS}$	$V_{GS}=\pm 12V, V_{DS}=0V$			$\pm 100$	nA
Zero Gate Voltage Drain Current	$I_{DSS}$	$V_{DS}=30V, V_{GS}=0V$			1	$\mu A$
Gate threshold voltage	$V_{GS(th)}$	$V_{DS}=V_{GS}, I_D=250\mu A$	0.5	0.9	1.3	V
Drain-source on-resistance	$R_{DS(on)}$	$V_{GS}=10V, I_D=3.5A$		19	27	m $\Omega$
		$V_{GS}=4.5V, I_D=3.0A$		20	30	m $\Omega$
		$V_{GS}=2.5V, I_D=2.5A$		28	45	m $\Omega$
Diode Forward Voltage	$V_{SD}$	$I_S=5.6A, V_{GS}=0V$			1.2	V
<b>Dynamic Parameters</b>						
Input Capacitance	$C_{iss}$	$V_{DS}=15V, V_{GS}=0V, f=1MHz$		630		pF
Output Capacitance	$C_{oss}$			55		pF
Reverse Transfer Capacitance	$C_{rss}$			71		pF
Turn-on Delay Time	$t_{d(on)}$	$V_{DS}=15V$ $V_{GS}=10V, R_{GEN}=3\Omega$ $I_D=5.6A$		4.4		ns
Turn-on Rise Time	$t_r$			28.2		ns
Turn-Off Delay Time	$t_{d(off)}$			16.2		ns
Turn-off Fall Time	$t_f$			26		ns
Total Gate Charge	$Q_g$				17.25	
Gate-Source Charge	$Q_{gs}$	$V_{DS}=15V, I_D=5.6A$ $V_{GS}=10V$		2.1		nC
Gate-Drain Charge	$Q_{gd}$			2		nC
Reverse Recovery Charge	$Q_{rr}$		$I_F=5.6A, di/dt=100A/\mu s$		1.1	
Reverse Recovery Time	$t_{rr}$			13.1		ns

A. Pulse Test: Pulse Width  $\leq 300\mu s$ , Duty cycle  $\leq 2\%$ .

B.  $R_{\theta JA}$  is the sum of the junction-to-case and case-to-ambient thermal resistance, where the case thermal reference is defined as the solder mounting surface of the drain pins.  $R_{\theta JC}$  is guaranteed by design, while  $R_{\theta JA}$  is determined by the board design. The maximum rating presented here is based on mounting on a 1 in 2 pad of 2oz copper.

# PARAMETER CHARACTERISTIC CURVE

**Fig 1: Output Characteristics**

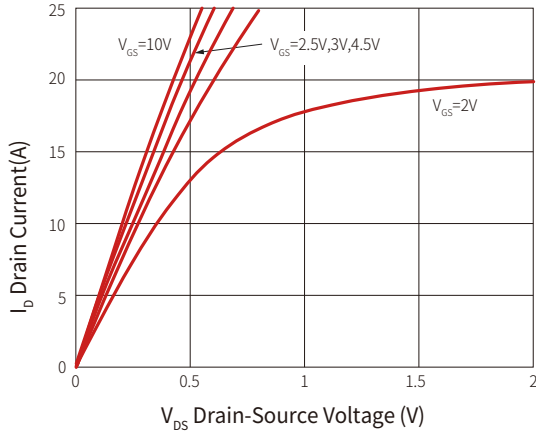

**Figure 2: Transfer Characteristics**

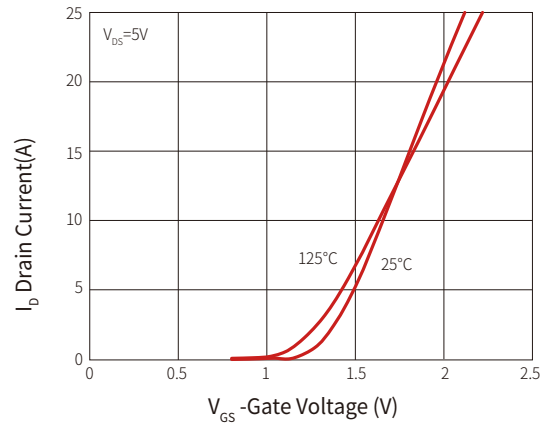

**Figure 3: On-Resistance vs. Drain Current and Gate Voltage**

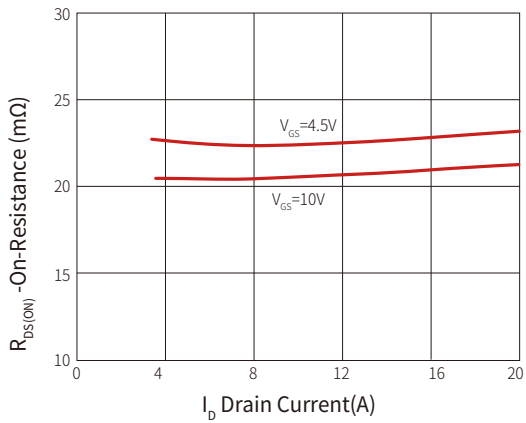

**Figure 4: On-Resistance vs. Junction Temperature**

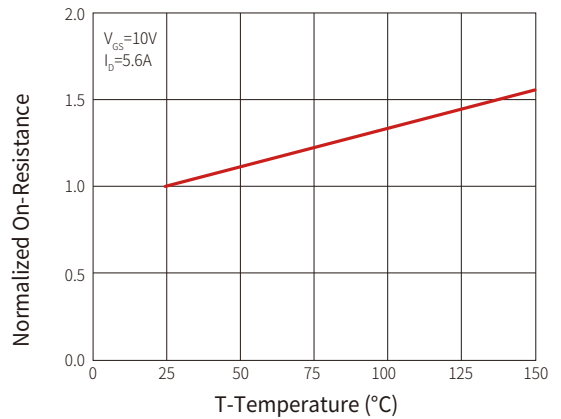

**Figure 5: Capacitance Characteristics**

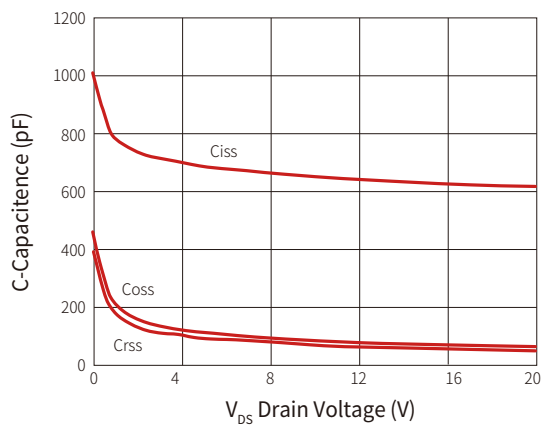

**Figure 6: Gate Charge**

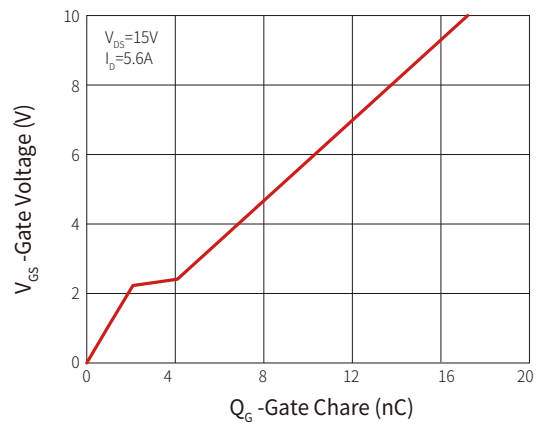

**Figure 7: Safe Operation Area**

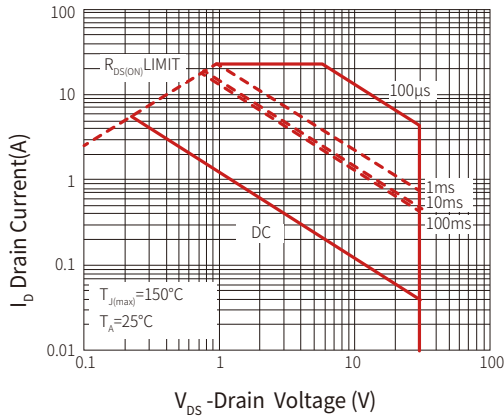

**Figure 8: Maximum Continuous Drain Current vs Ambient Temperature**

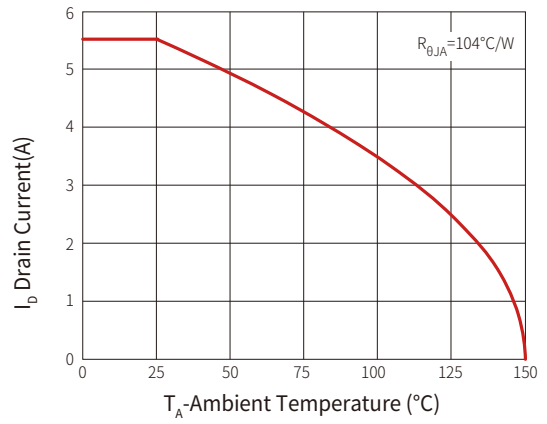

**Figure 9: Normalized Threshold voltage**

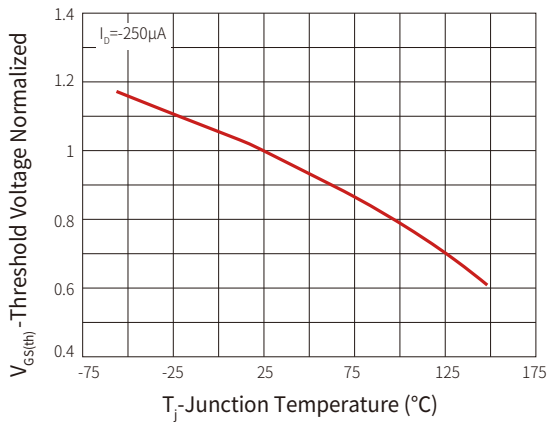

**Figure 10: Normalized Maximum Transient Thermal Impedance**

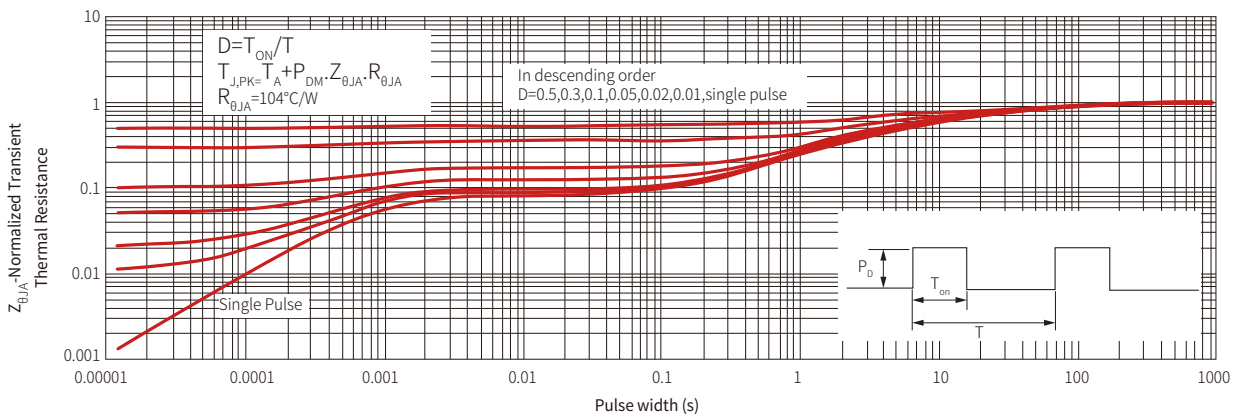

## SOT-23-3L PACKAGE INFORMATION

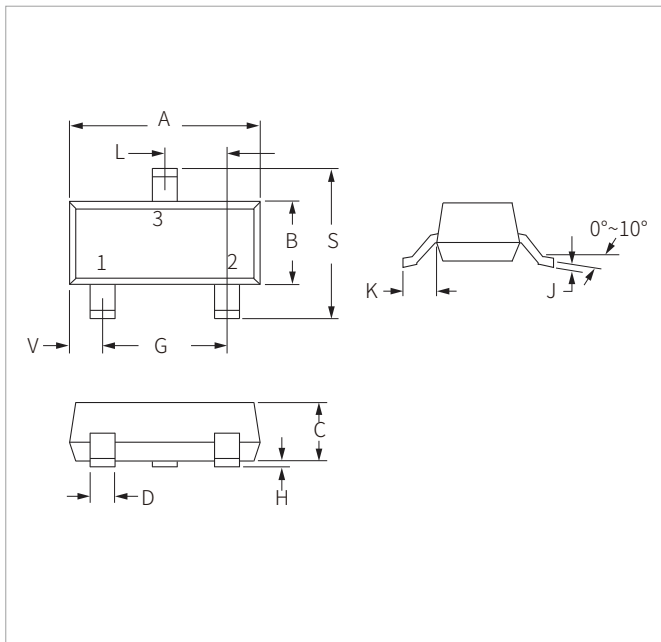

Ref.	Millimeters		Inches	
	Min.	Max.	Min.	Max.
A	2.80	3.15	0.110	0.124
B	1.50	1.70	0.060	0.070
C	1.00	1.30	0.039	0.051
D	0.37	0.50	0.015	0.020
G	1.78	2.10	0.070	0.083
H	0.01	0.15	0.001	0.006
J	0.08	0.18	0.003	0.007
K	0.35	0.69	0.014	0.029
L	0.89	1.02	0.035	0.040
S	2.60	3.00	0.102	0.118
V	0.45	0.60	0.018	0.024

## RECOMMENDED PAD LAYOUT DIMENSIONS

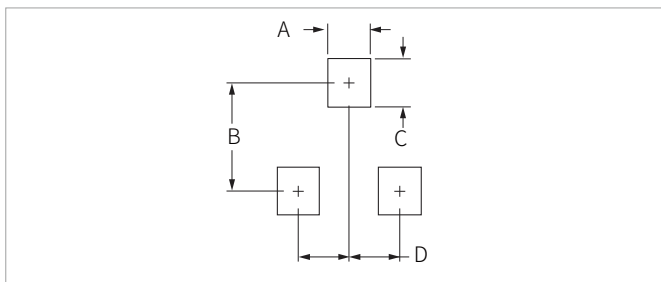

Ref.	Millimeters		Inches	
	Min.	Max.	Min.	Max.
A	0.70	1.00	0.028	0.039
B	2.30	2.50	0.090	0.098
C	0.70	1.00	0.028	0.039
D	0.80	1.10	0.032	0.043

## ORDERING INFORMATION

Part Number	Component Package	QTY/Reel	Reel Size
SNM3400AQ	SOT-23-3L	3000PCS	7"

**Headquarters**

No.3387 Shendu Road  
Pujiang I&E Park  
Minhang Shanghai China  
201000

**Hotline**

400-021-5756

**Web**

<https://www.semiware.com>

**Sales Center**

Tel: 86-21-3463-7458  
Email: [sales18@semiware.com](mailto:sales18@semiware.com)

**Customer Service**

Tel: 86-21-5484-1001  
Email: [sales17@semiware.com](mailto:sales17@semiware.com)

**Technical Support**

Tel: 86-21-3463-7654  
Email: [fae01@semiware.com](mailto:fae01@semiware.com)

**Complaint & Suggestions**

Tel: 86-21-3463-7172  
Ext: 8868  
Email: [cs03@semiware.com](mailto:cs03@semiware.com)

**By QR Code**

Website



Wechat

To find your local partner within Semiware' s global website: [www.semiware.com](http://www.semiware.com)

© 2022 Semiware Semiconductor Inc.

The content of this document has been carefully checked and understood. However, neither Semiware nor its subsidiaries assume any liability whatsoever for any errors or inaccuracies of this document and the consequences thereof. Published specifications are subject to change without notice. Product suitability for any area of application must ultimately be determined by the customer. In all cases, products must never be operated outside their published specifications. Semiware does not guarantee the availability of all published products. This disclaimer shall be governed by substantive Chinese law and resulting disputes shall be settled by the courts at the place of business of Semiware. Latest publications and a complete disclaimer can be downloaded from the Semiware website. All trademarks recognized.